



## S300FX-GX

Combination HEPA Filter/  
UV air sterilization system



The S300FX-GX is designed for applications that require filtration as well as purification. The included HEPA Filter is 99.97% effective, trapping particles down to 0.3 microns in size. Purification is done through Germicidal Photo-Oxidation. The air is pulled into the Aluminum UV Reaction Chamber where the air is made to pass parallel to the UV Lamp, bombarding it with UVC & UVV light, destroying the biological & chemicals in the air. The air continues to pass through the pre-filter and finally the HEPA filter.

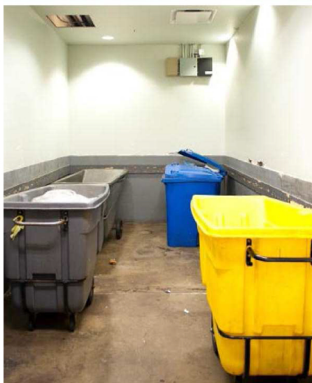

By combining HEPA Filtration & UV Purification, Sanuvox is able to offer a complete IAQ solution in one unit.

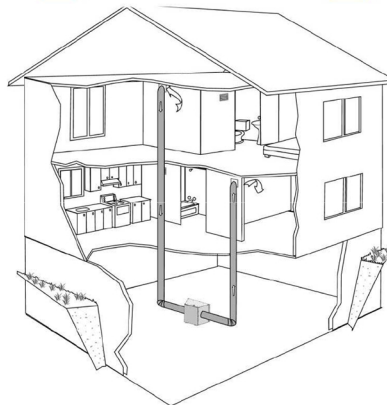
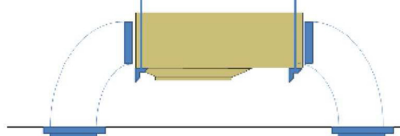

## S300FX-GX FEATURES

- 2" pre-filter & True 2.5" HEPA Filter captures particles down to 0.3 micron in size
- Destroys biological contaminants such as mold, bacteria, viruses, germs, allergens
- Duct mounted or stand-alone installation
- 300 cfm 2 speed blower
- Patented 19 mm. Pure Fused Quartz UVC/UVV Lamp
- Reflecting Box maximizes UV intensity
- High-Output Ballast
- Patented Design & Sanuvox Quality
- CSA/US Certified & CE Approved

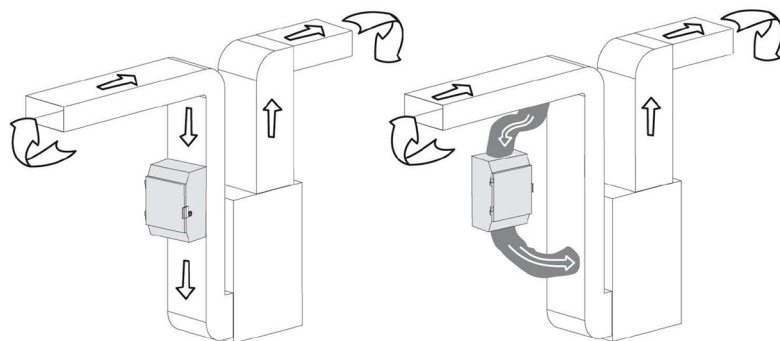

ANSR SDN BHD